

PC Board Layout

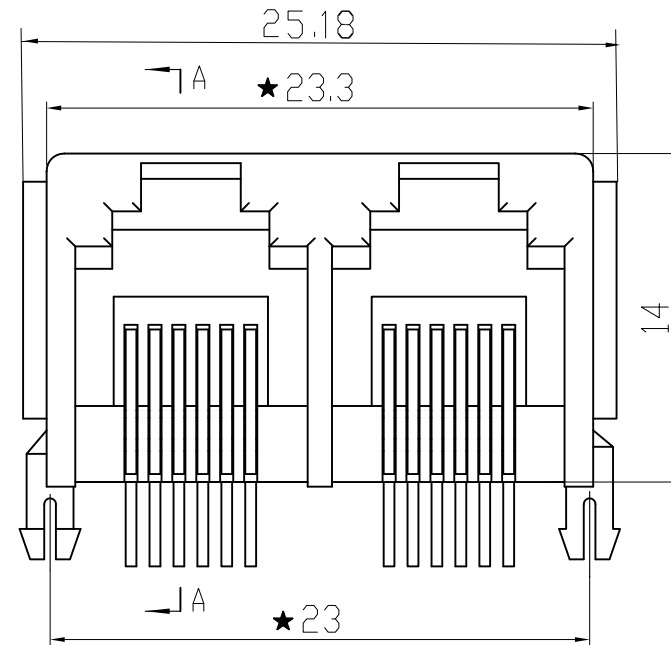
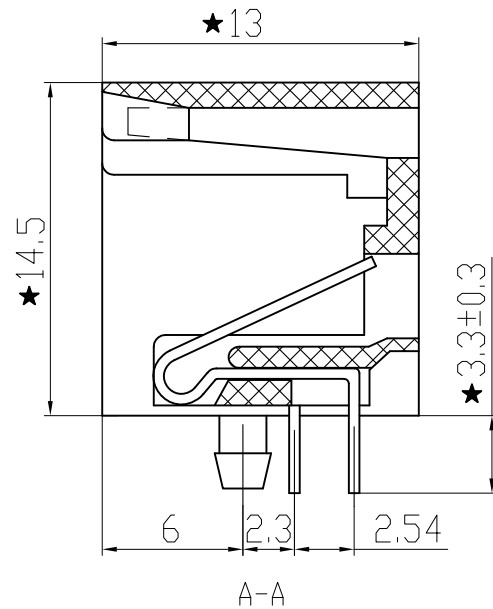
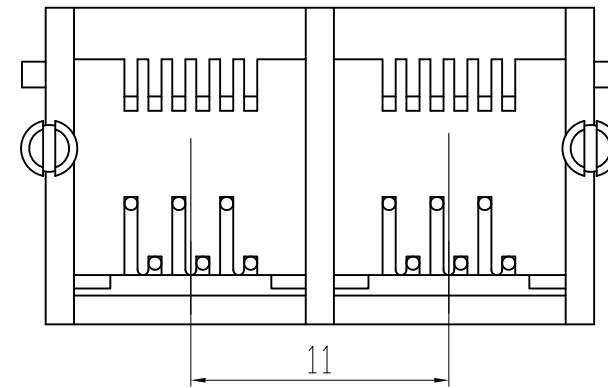

PCB JACK Specification

1. Insulation Resistance: 500MΩMIN @ 500 VDC
2. Withstanding Voltage: AC1000V 50Hz or 60Hz 1min.
3. Durability: 600 Mating Circles MIN.
4. Gold Plating: (3;6;15;30;50)u inch

Remark:

1. The mark with ★ is the key inspection dimension for QC

Tolerances Unless		TELL					Coorle 库乐科技		
0~10mm	±0.1	Fax							
11mm~20mm	±0.2	Units	MM	Drawing			Material	Name	5521 6P6C 1X2-E
21mm~40mm	±0.3	Scale	1 : 1	Check					
41mm~80mm	±0.4	Rev'	A / 1	Approval			HOUSING	PBT	Part Number
81mm~150mm	±0.5	View		Date	2008/06/05	PIN	Qsn6.5-0.1	File Name	